

CLOCS-A

Gold Requirements

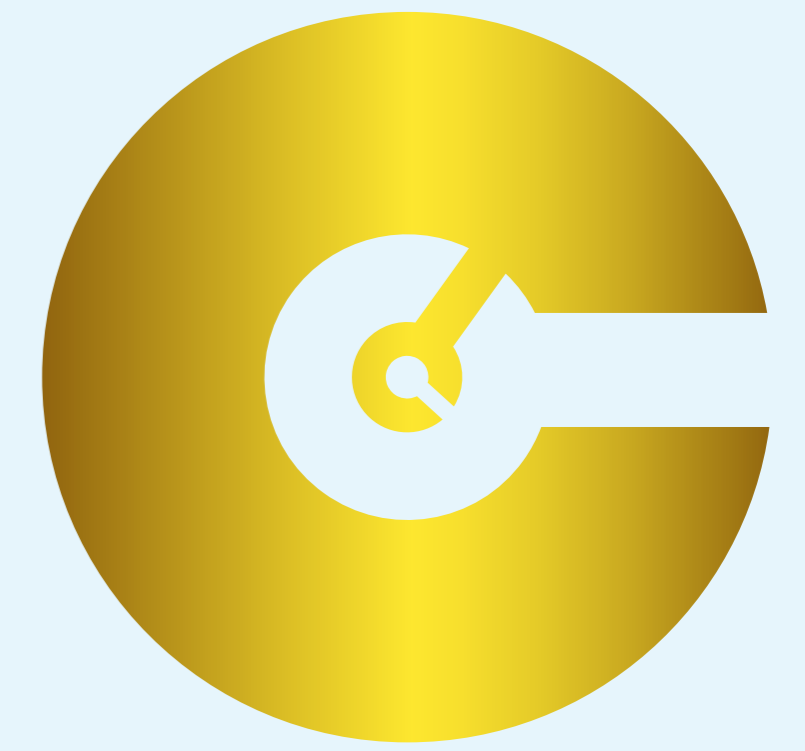

Telematics

Electronic Stability Control – Trucks

Advanced Emergency Braking



Autonomous Reverse Braking

Euro VI Emission Standard

or

Zero Emission Vehicle

Roll Stability Control – Trailers

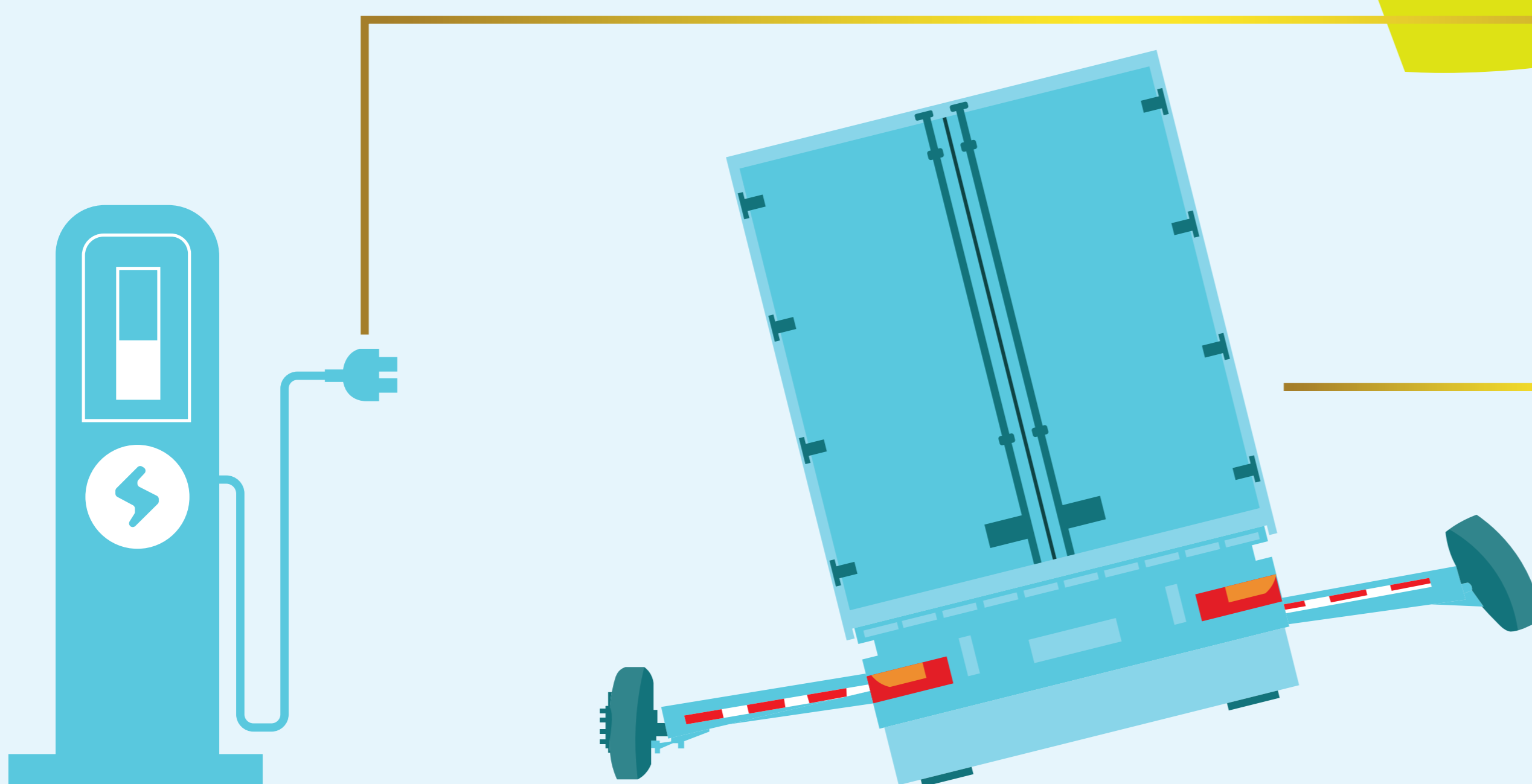

The highest standard of equipment that is being sought for heavy vehicles complying with CLOCS-A technical requirements. Encourages leading safety technologies & to future-proof vehicles. Accreditation to Gold also requires prior accreditation to Silver.

No bug deflectors on bonnetted trucks – City and Urban Projects only

No engine air intake hardware above bonnet level – City and Urban Projects only

No large inappropriate bullbars – City and Urban Projects only

No inappropriate sunvisors

No overly large decals or lettering attached to any part of the windscreen that may reduce the driver's field of view

No excessive windscreen or window tinting

No inappropriate fitment of aftermarket accessories that restrict the driver's field of view

